



Irish Amateur Archery Association Ltd

Cumann Boghdóireacht Amaitéireach na hÉireann Teo

Affiliated to: Olympic Council of Ireland and F.I.T.A.

AFFILIATE CLUB RENEWAL FORM 2011

This form must be completed in BLOCK CAPITALS throughout, except where signatures are required.

Name of Club

Chairman's / President's Details

Name

Address

Email

Phone IAAA member number

Garda Vetted yes no Basic Awareness Course completed yes no

Children's Officer Course completed yes no

Signature Date

Secretary's Details

Name

Address

Email

Phone IAAA member number

Garda Vetted yes no Basic Awareness Course completed yes no

Children's Officer Course completed yes no

Signature Date

Treasurer's Details

Name

Address

Email

Phone IAAA member number

Garda Vetted yes no Basic Awareness Course completed yes no

Children's Officer Course completed yes no

Signature Date

Athlete Protection Officer Details (formerly Children's Officer)

Name

Address

Email

Phone IAAA member number

Garda Vetted yes no Basic Awareness Course completed yes no

Children's Officer Course completed yes no

Signature Date

Designated Person Details

Name

Address

Email

Phone IAAA member number

Garda Vetted yes no Basic Awareness Course completed yes no

Children's Officer Course completed yes no

Signature Date

Coach's Details

Name

Address

Email

Phone IAAA member number

Garda Vetted yes no Basic Awareness Course completed yes no

Coach ID number Children's Officer Course completed yes no

Signature Date

Line Manager Details

Name

Address

Email

Phone IAAA member number

Garda Vetted yes no Basic Awareness Course completed yes no

Line Manager trained yes Children's Officer Course completed yes no

Signature Date

Use the space below if you wish to notify the Association of further post holders.

Details

Name

Address

Email

Phone IAAA member number

Garda Vetted yes no Basic Awareness Course completed yes no

Children's Officer Course completed yes no

Signature Date

Details

Name

Address

Email

Phone IAAA member number

Garda Vetted yes no Basic Awareness Course completed yes no

Children's Officer Course completed yes no

Signature Date

Details of Training / Competition Venues Type: Indoors Outdoors

Address

Training Times:

Mon : to : Tues : to : Wed : to :

Thur : to : Fri : to : Sat : to :

Sun : to :

For IAAA Use Only

Venue inspected by Date

Details of Training / Competition Venues Type: Indoors Outdoors

Address

Training Times:

Mon : to : Tues : to : Wed : to :

Thur : to : Fri : to : Sat : to :

Sun : to :

For IAAA Use Only

Venue inspected by Date

Details of Training / Competition Venues Type: Indoors Outdoors

Address

Training Times:

Mon : to : Tues : to : Wed : to :

Thur : to : Fri : to : Sat : to :

Sun : to :

For IAAA Use Only

Venue inspected by Date

Details of Training / Competition Venues Type: Indoors Outdoors

Address

Training Times:

Mon : to : Tues : to : Wed : to :

Thur : to : Fri : to : Sat : to :

Sun : to :

For IAAA Use Only

Venue inspected by Date

Details of Club Colours

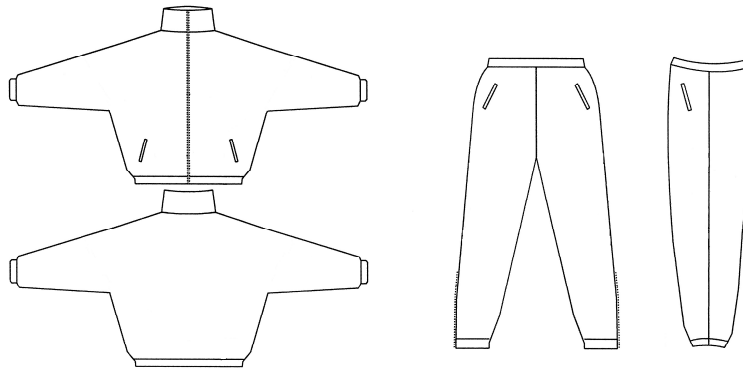

Declaration

To be approved as an Affiliate Club of the Association, the officers and members of your club must be aware of the obligations that are involved, particularly as they apply to safety, conduct and working with young children in sport. By signing this declaration, the named officers declare that they have read, understood, accept and agree to abide by the contents and guidelines contained in the IAAA document titled 'Code of Conduct for Children's Sport'. Additionally, they undertake to run the club according to the guidelines contained therein.

We, the officers of the above-named club, hereby declare that we wish for our club to be affiliated to the Irish Amateur Archery Association Ltd. and we do hereby agree to abide by the Code of Ethics, Constitution, rules and byelaws of the association and comply with vetting procedures.

President Date

Secretary Date

Treasurer Date

Detail of fees

Note that every club must pay the Affiliation Fee **and** the National Medals Fee. The National Medals Fee is paid by all clubs so that the clubs hosting National or Open competitions do not bear the entire cost of providing National Medals. Fees for FITA stars must be paid if you wish your club competition to be registered with FITA and scores to count towards FITA awards.

Club Affiliation Fee € 249 National Medals Fee € 60 FITA Star Fee € 41

Amount enclosed

€

For IAAA use only

Date Received

Reviewed and accepted
At NEC Meeting date

Please return the completed form, **with fees** to
Hon.Secretary IAAA, Mr. Robert Clarke, 14 Glendale, Leixlip, Co. Kildare.
See www.archery.ie for further information about the IAAA and archery in Ireland.